

TECHNICAL INSTALLATION MANUAL

IRREVERSIBLE OPERATOR FOR SWING GATES AND DOORS

PM1/SC



WARNING!! Before installing, thoroughly read this manual that is an integral part of the pack

Our products if installed by qualified personnel capable to evaluate risks, comply with norms UNI EN 12453, EN 12445



The CE mark conforms to European directive
EEC 89/336 + 92/31 + 93/68 D.L. 04/12/1992 N. 476.

INDEX

	Pag.
PACKING CONTENTS	2
VIEW OF TYPICAL AUTOMATION AND NAMES OF COMPONENTS	3
TECHNICAL DATA.....	3
DIMENSIONS	4
TYPICAL CONNECTION AND CABLE SECTION.....	4
CONSIDERATIONS FOR INSTALLATION.....	5
INSTALLATION.....	5-6
TROUBLESHOOTING.....	7
SAFETY PRECAUTIONS	8

PACKING CONTENTS

1- OPERATOR



1- KIT FASTENING PLATES AND
RELATIVE ACCESSORIES

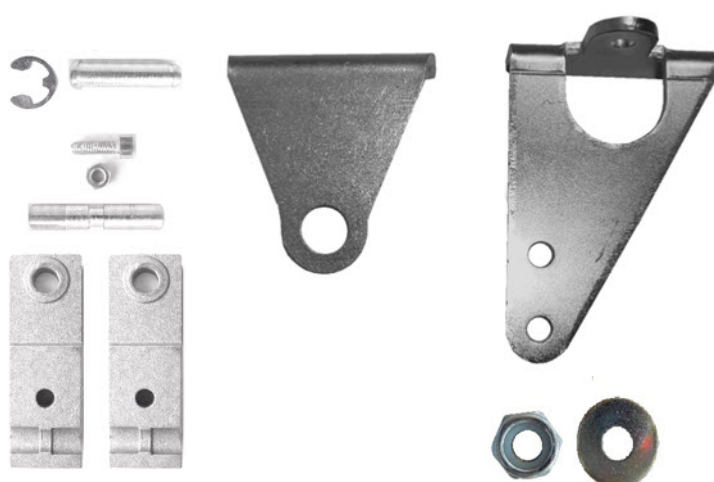

1- UNLOCKING KEY

1- CONDENSER (230Vca)



VIEW OF TYPICAL AUTOMATION AND NAMES OF COMPONENTS

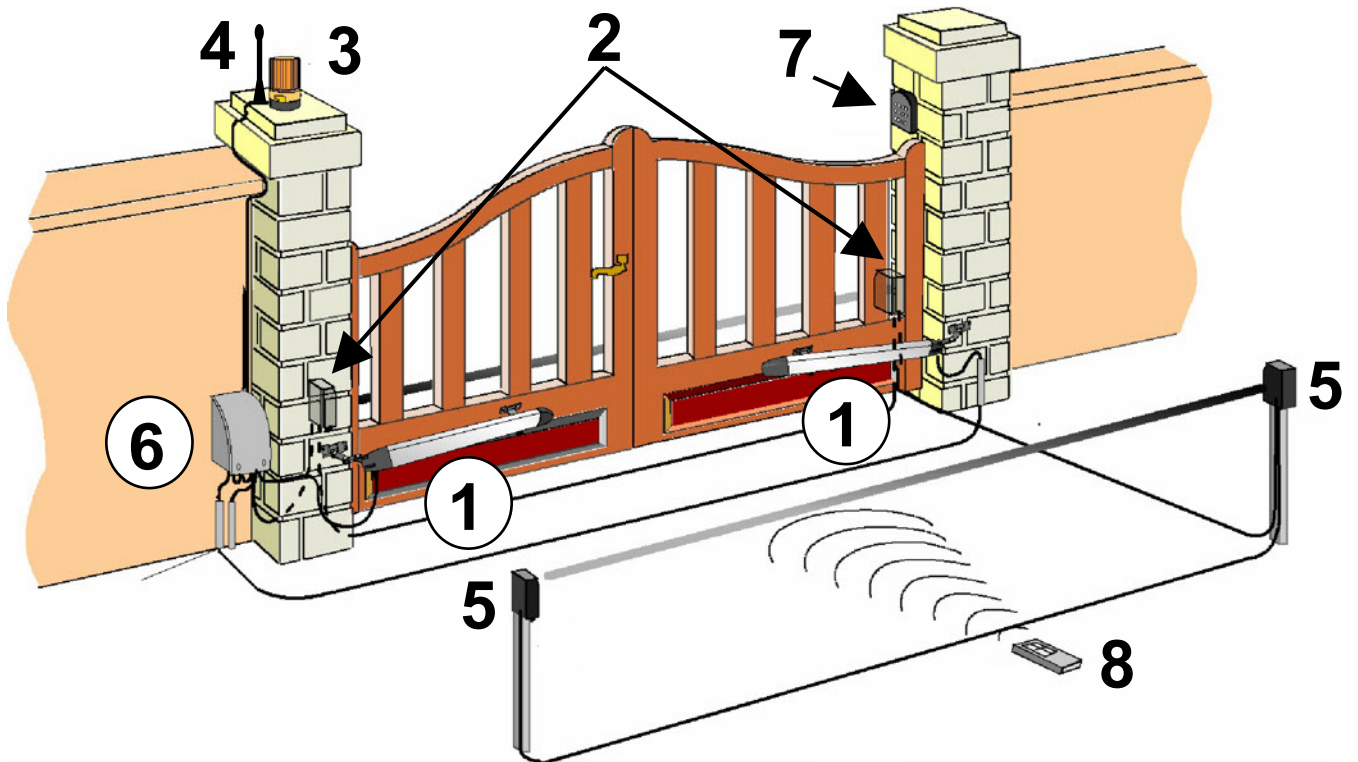

Optimal installation

- | | |
|---------------------------|----------------------------|
| 1- Operator | 5- Internal photocell |
| 2- External photocell | 6- Electronic control unit |
| 3- Flashing warning light | 7- Key-switch |
| 4- Antenna | 8- Remote control |

TECHNICAL DATA

Max. weight of gate	200 Kg	
Max. width of gate	2,50 mt	
Motors power supply	24Vdc	230 Vac
Motor power	50 W	200 W
Motor RPM	1500	1400
Condenser	/	16 μ F
Mechanical unlock for emergency manoeuvre	With key	
Working temperature	-20° C / +55° C	
weight	6.5 Kg	
Protection rating	IP 55	
Opening time 90°	15 sec	
Rod stroke	300/400/500 mm	
Force of thrust	1500 N	
Motor current input	3 A	1 A

DIMENSIONS

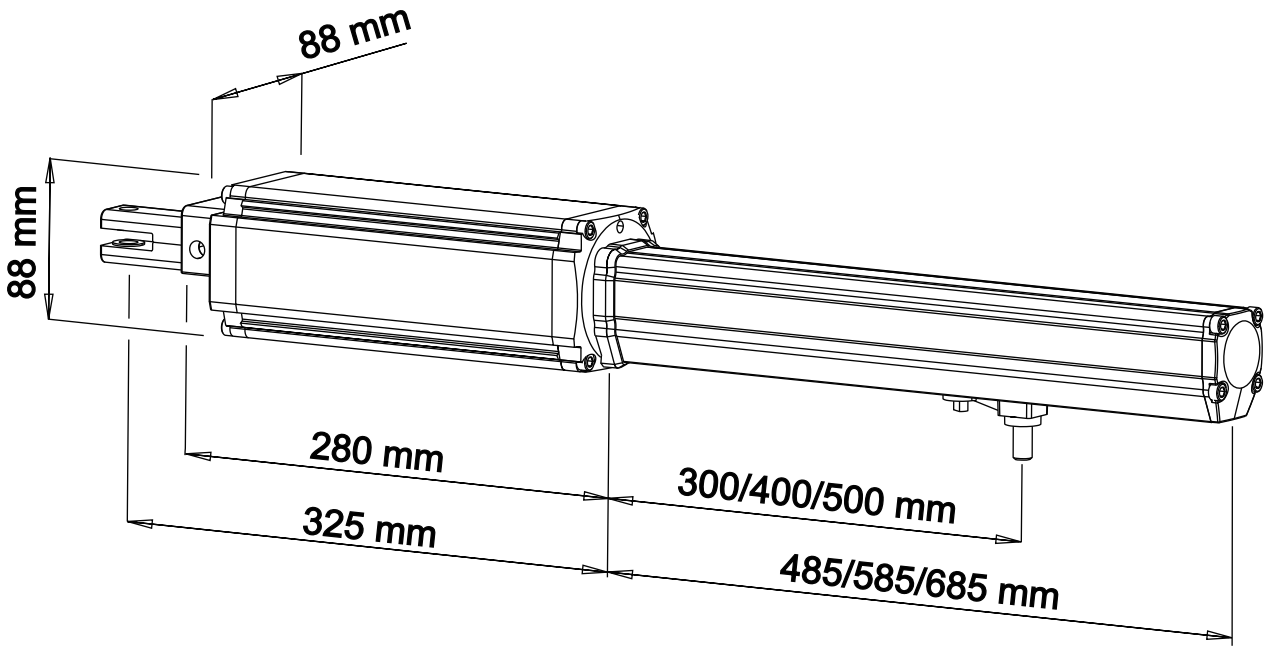

TYPICAL CONNECTION AND CABLE SECTION

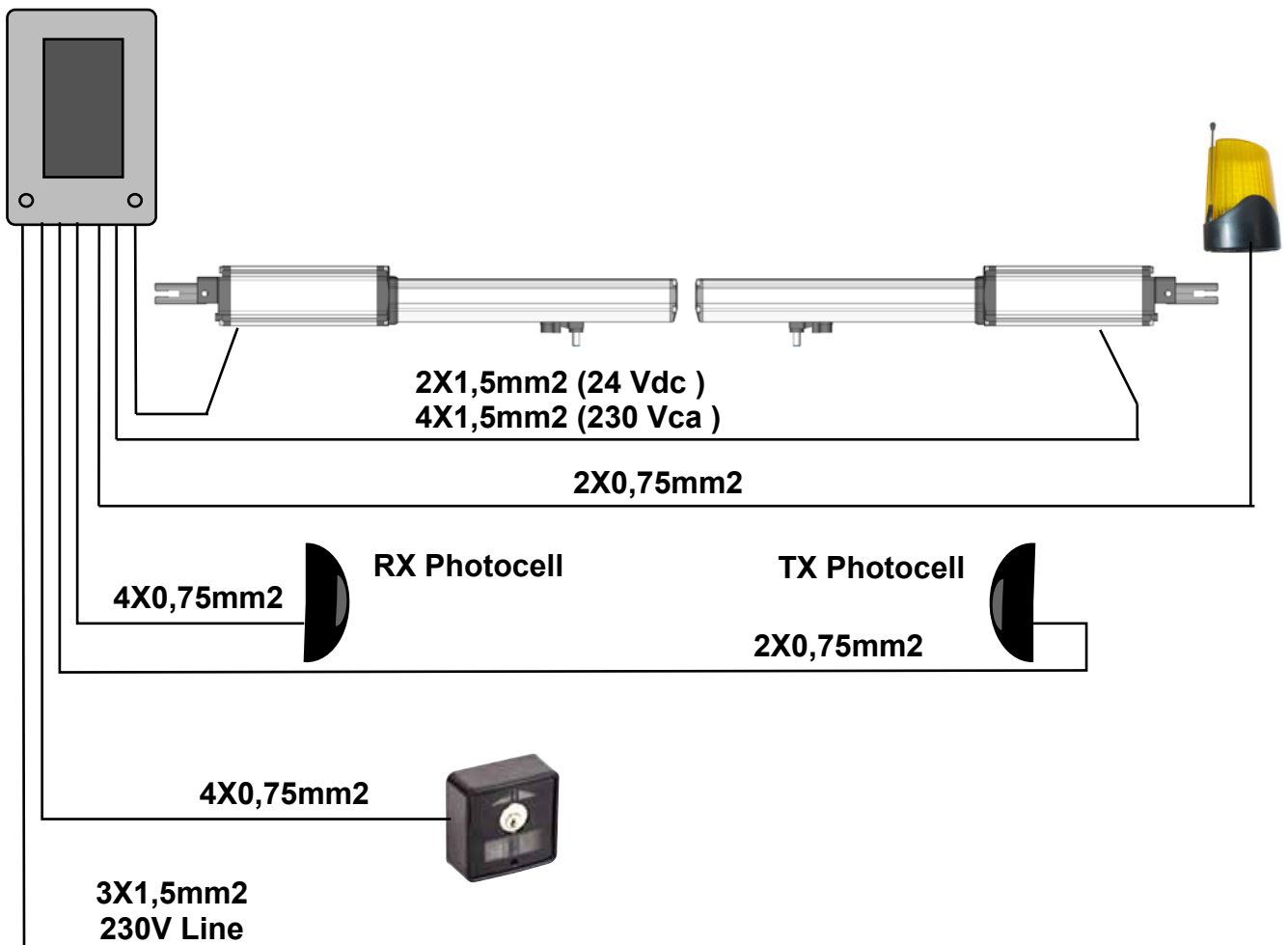

CONSIDERATIONS FOR INSTALLATION

- The installation and testing operations must be performed solely by qualified personnel in order to guarantee the proper and safe operation of the automatic gate.
- The company declines any responsibility for damage caused by incorrect installations due to incompetence and/or negligence.
- Before assembling the automatism, check that the gate is in perfect working order, hangs well on its hinges and is suitably lubricated. It must also comply with the safety standards in force in the country of installation..

INSTALLATION

1. Before fastening the brackets provided, establish the coordinates using the data given in **Table 1**, bearing in mind that they are valid if the operator is at maximum extension minus one centimetre of the available stroke (**CD**) when the gate is closed to obtain maximum working efficiency.
2. Data **B** in the table, with reference to the single values **A**, are to be considered as values (recommended).
3. To anchor the piston, use the fastening brackets provided.

COORDINATES AND TABLE

1. Establish coordinates **A + B** that are to be used.
2. **Note:** The stroke used (**CU**) of the operator must never be equal or greater than the available stroke (**CD**)
3. The sum of coordinates **A + B**, establishes the stroke used **CU**.

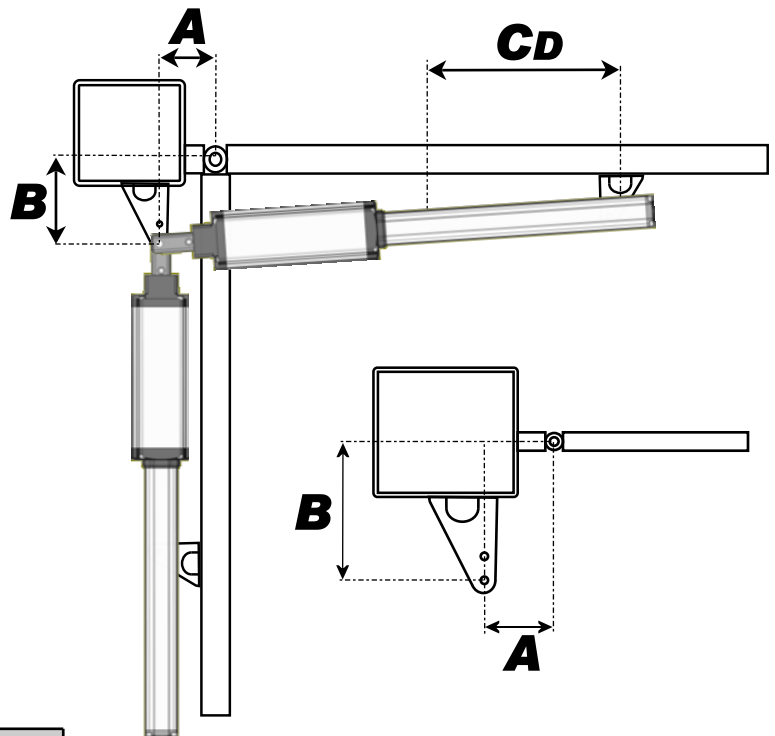

TABLE 1

Opening angle	A	B	Cu
90	80	80	160
	90	90	180
	100	100	200
	100	150	250
100	110	110	220
	120	120	240
	120	100	220
110	130	130	260
	140	140	280
	150	150	300

Opening angle	A	B	Cu
90° Available stroke = 400mm	160	160	320
	175	175	350
	190	190	380
	200	200	400
90° Available stroke = 500mm	250	250	500

Note1: A+B = CU (Stroke used) CD = (Available stroke) = 300/400/500 mm

INSTALLATION OF FASTENING PLATES

Fix the back plate to the pillar. **(FIG. 1)**

Anchor the rear part of the piston to the plate and fasten it firmly **(FIG. 2)**

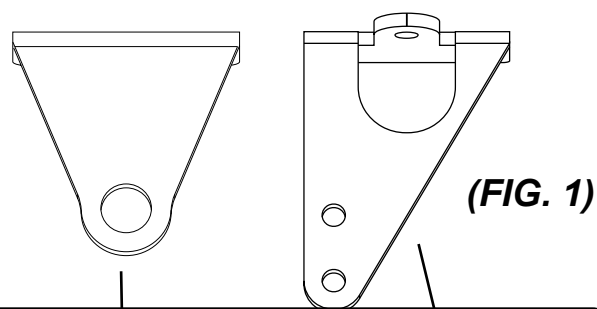

(FIG. 1)

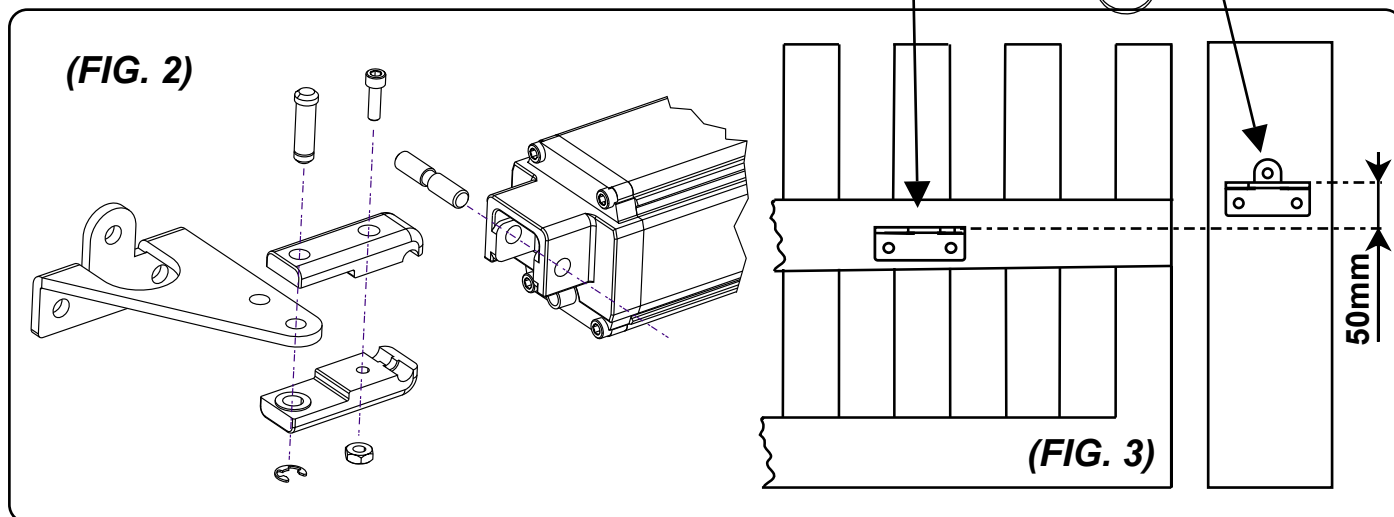

(FIG. 2)

(FIG. 3)

Warning! When establishing the height off the ground at which to fasten the plate **(FIG.1)** onto the post, keep in mind the height at which the plate will be fastened **(FIG.3)** for anchoring the piston to the gate and that the plate must be fastened 50 mm below that on the post to obtain horizontal levelling.

Installing the anchor plate on the piston to the gate

1. Fit the anchor plate onto the piston **(fig. 4)**
2. Close the gate
3. Move the piston with the plate already fitted towards the gate
4. Move the fitting to limit stop, then move it back by approximately 1 cm and mark the position of the plate.
5. realize the same operation in opening.
6. If positions correspond, fix the plate on the gate; otherwise revise **A** and **B** units **(table 1)**

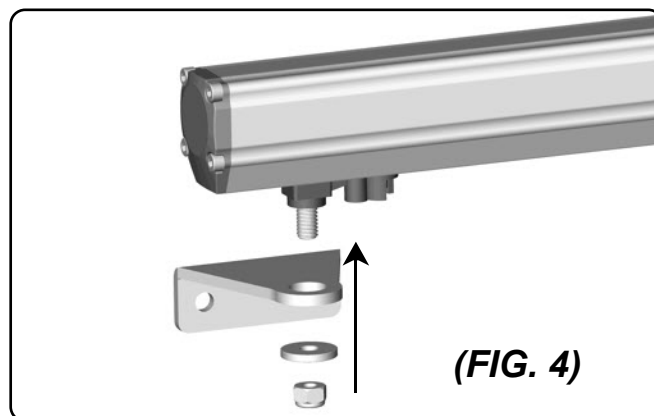

(FIG. 4)

Release procedure

To unblock the operator, use the key as shows the photo.

Turning the key of 90°, the operator will be completely unblocked.

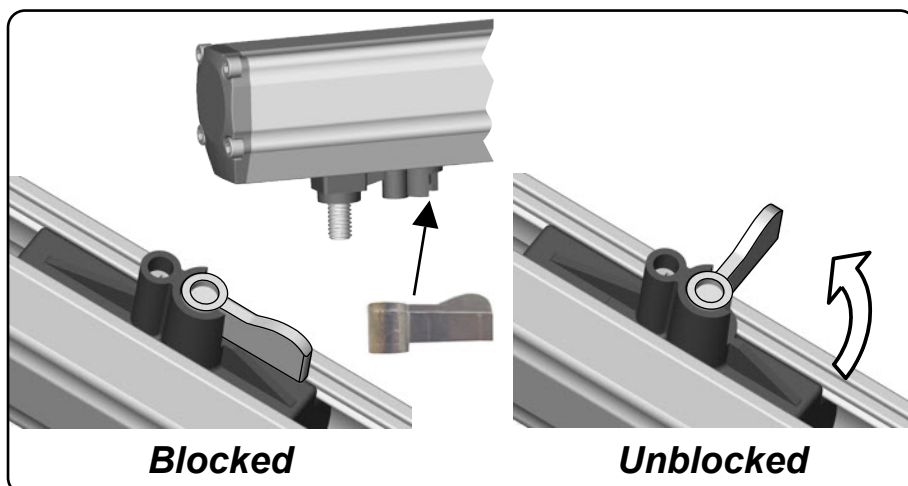

Blocked

Unblocked

TROUBLESHOOTING

PROBLEM	PROBABLE CAUSE	SOLUTION
On giving a command with the remote control or with the key-switch, the gate doesn't open or the motor doesn't start	230 volt mains voltage absent	Check master switch
	Emergency STOP present	Check for any STOP selectors or commands. If not used, check jumper on STOP contact input on the control board
	Fuse blown	Replace with one of same value.
	Power cable of motor or motors not connected or faulty.	Connect the cable to appropriate terminal or replace.
	The photocell is not functioning or the beam is interrupted	Check the connection, remove any obstacle across the beam
On giving a command with the remote control, the gate doesn't open but works with the key command	The remote control has not been memorised or the battery is flat	Carry out the remote control learning procedure on the radio receiver or replace the battery with a new one..
The gate starts, but stops immediately	The force of the motor or motors is insufficient	Modify the value with the FORCE trimmer on the control unit
One wing opens and the other closes	The connection is not correct	Invert the connection of the cable of the motor which rotates in the wrong sense

N.B. - If the problem persists, contact your Retailer or the nearest Service Centre

SAFETY PRECAUTIONS

These warnings are an essential, integral part of the product and must be given to the user. They provide important indications on the installation, use and maintenance and must be read carefully. This form must be preserved and passed on to subsequent users of the system. The incorrect installation or improper use of the product may be dangerous.

INSTALLATION INSTRUCTIONS

- The installation must be performed by professionally skilled personnel and in compliance with current local, state, national and European legislation.
- Before beginning the installation, check the integrity of the product.
- The laying of cables, electrical connections and adjustments must be workmanlike performed.
- The packing materials (cardboard, plastic, polystyrene, etc.) are a potential hazard and should be disposed of correctly and not left within reach of children.
- Do not install the product in potentially explosive environments or environments disturbed by electromagnetic fields. The presence of inflammable gases or fumes is a grave danger to safety.
- Set up a safety device for overvoltage, a disconnecting and/or differential switch suitable for the product and conforming to current standards.
- The manufacturer declines any and all responsibility for product integrity, safety and operation in the event incompatible devices and/or components are installed.
- Solely original spare parts should be used for repairs and replacements.
- The installer must provide all the information relating to the operation, maintenance and use of the individual parts, components and system as a whole.

WARNINGS FOR THE USER

- Read the instructions and enclosed documentation carefully.
- The product must be used for the express purpose for which it was designed. Any other use is considered improper and therefore hazardous. In addition, the information given in this document and in the enclosed documentation may be subject to modifications without prior notice. It is given as an indication only for product application. The company declines any responsibility for the above.
- Keep products, devices, documentation and anything else provided out of reach of children. In the event of maintenance, cleaning, breakdown or faulty operation of the product, cut off the power and do not attempt to operate on the product. Contact solely the professionally skilled personnel responsible for these operations. Failure to adhere to the above indications may be dangerous.

All products are guaranteed for 2 years, as per the date on the invoice or on the receipt.

The warranty also does not include: failures or damages caused by faults of the electrical system and/or carelessness, negligence or inadequacy of the installation to the use for which it is intended and in any case from abnormal use; failures or damages due to tampering by unauthorized personnel or the use of components not attributable to the manufacturer and/or non-original spare parts; defects caused by chemical agents, external bodies or atmospheric and/or natural phenomena in general; failures or damages caused by incorrect installation of the Products according to the rule of art, safety and conformity of use expressly indicated in the technical documentation of the same Products; the consumables; interventions for checks and assessments of any flaws or defects then not found; compensations for the period of inactivity of the system where the Products are installed.

The data and images are for guidance only

VDS reserves the right to change at any time characteristics of the products described in its sole discretion, without notice.



Via Circolare p.i.p. N° 10
65010 Santa Teresa di Spoltore (PE) - ITALY
Tel. +39 085 4971946 - FAX +39 085 4973849
www.vdsautomation.com - info@vdsautomation.it