

# TECHNICAL INSTALLATION MANUAL

## MOTOR FOR GARAGE DOORS COUNTERWEIGHT OVERHEAD DOORS

# BASIC ON



**WARNING!!** Before installing, thoroughly read this manual that is an integral part of the pack

Our products if installed by qualified personnel capable to evaluate risks, comply with norms UNI EN 12453, EN 12445



The CE mark conforms to European directive  
EEC 89/336 + 92/31 + 93/68 D.L. 04/12/1992 N. 476.

# INDEX

	Pag.
PACKING CONTENTS .....	2
TECHNICAL DATA.....	2
DIMENSIONS .....	3
VIEW OF TYPICAL AUTOMATION AND NAMES OF COMPONENTS .....	3
CONSIDERATIONS FOR INSTALLATION.....	3
INSTALLATION.....	4-5-6-7
TROUBLESHOOTING.....	8
SAFETY PRECAUTIONS .....	11

## PACKING CONTENTS

- 1- MOTOR WITH CARTER AND COURTESY LIGHT
- 1- PACK OF ACCESSORIES
- 1- CAPACITOR

## OPTIONAL

- 1- CONTROL BOARD WITH RECEIVER



## TECHNICAL DATA

	230V	24V
<b>Max door width</b>	<b>10 mq</b>	
<b>Motor power supply</b>	<b>230Vac</b>	<b>24Vdc</b>
<b>Motor power</b>	<b>250 W</b>	<b>50W</b>
<b>Motor rpm</b>	<b>1400</b>	<b>1800</b>
<b>Capacitor</b>	<b>12,5 µF</b>	<b>/</b>
<b>Average power consumption</b>	<b>1.3 A</b>	<b>3 A</b>
<b>Mechanical release for emergency operation</b>	<b>Indoor use with possibility of outdoor use</b>	
<b>Working temperature</b>	<b>-20° C / +55° C</b>	
<b>Weight</b>	<b>8Kg</b>	
<b>Protection rating</b>	<b>IP 30</b>	
<b>Limit switch</b>	<b>Electromechanical</b>	

---

## DIMENSIONS

---

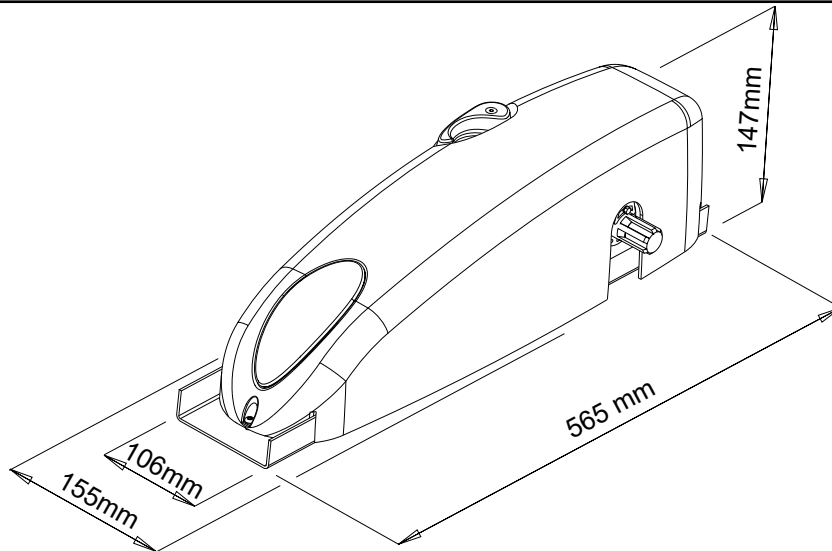

---

## VIEW OF TYPICAL AUTOMATION AND NAMES OF COMPONENTS

---

1. FIXING PLATE OF THE MOTOR
2. MOTOR
3. ARMS KIT
4. SAFETY EDGE
5. PHOTOCELLS
6. FLASHING LIGHT + ANTENNA
7. CONTROL BOARD (IF NOT INCLUDED IN THE MOTOR)

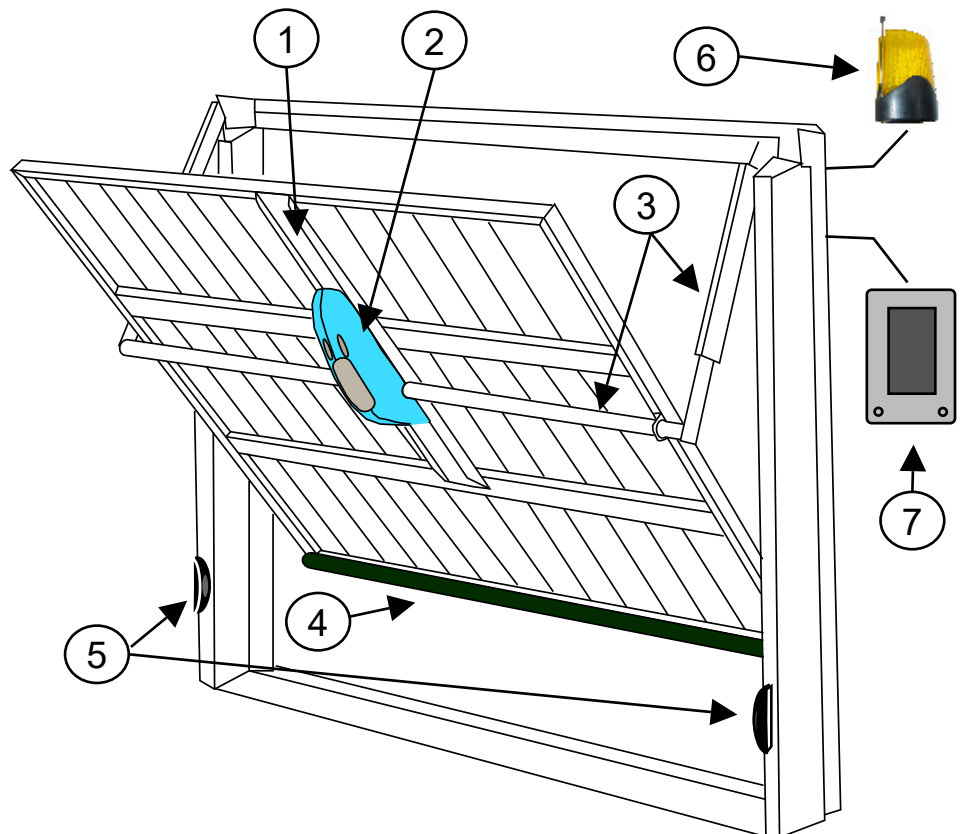

---

## CONSIDERATIONS FOR INSTALLATION

---

- The installation and testing operations must be performed only by qualified personnel in order to ensure the proper and safe operation of the automated door.
- The manufacturer declines all responsibility for damages caused by incorrect installations due to incompetence and/or negligence.
- Before installing the automation, check that the door is perfectly working and balanced.

**Note:** The increase of counterweights is equal to the weight of the frame that you will install on the door in addition to the weight of the motor.

# INSTALLATION

Place and securely fix the anchor plate of the telescopic arm to the door frame so that the movement of the arm does not overlap with the existing arm of the door. Make sure there are at least 20 mm of space between the door frame and the box of the counterweights.

**Note: If you are not able to use the straight telescopic arm, use the curved one**

Fig. 1

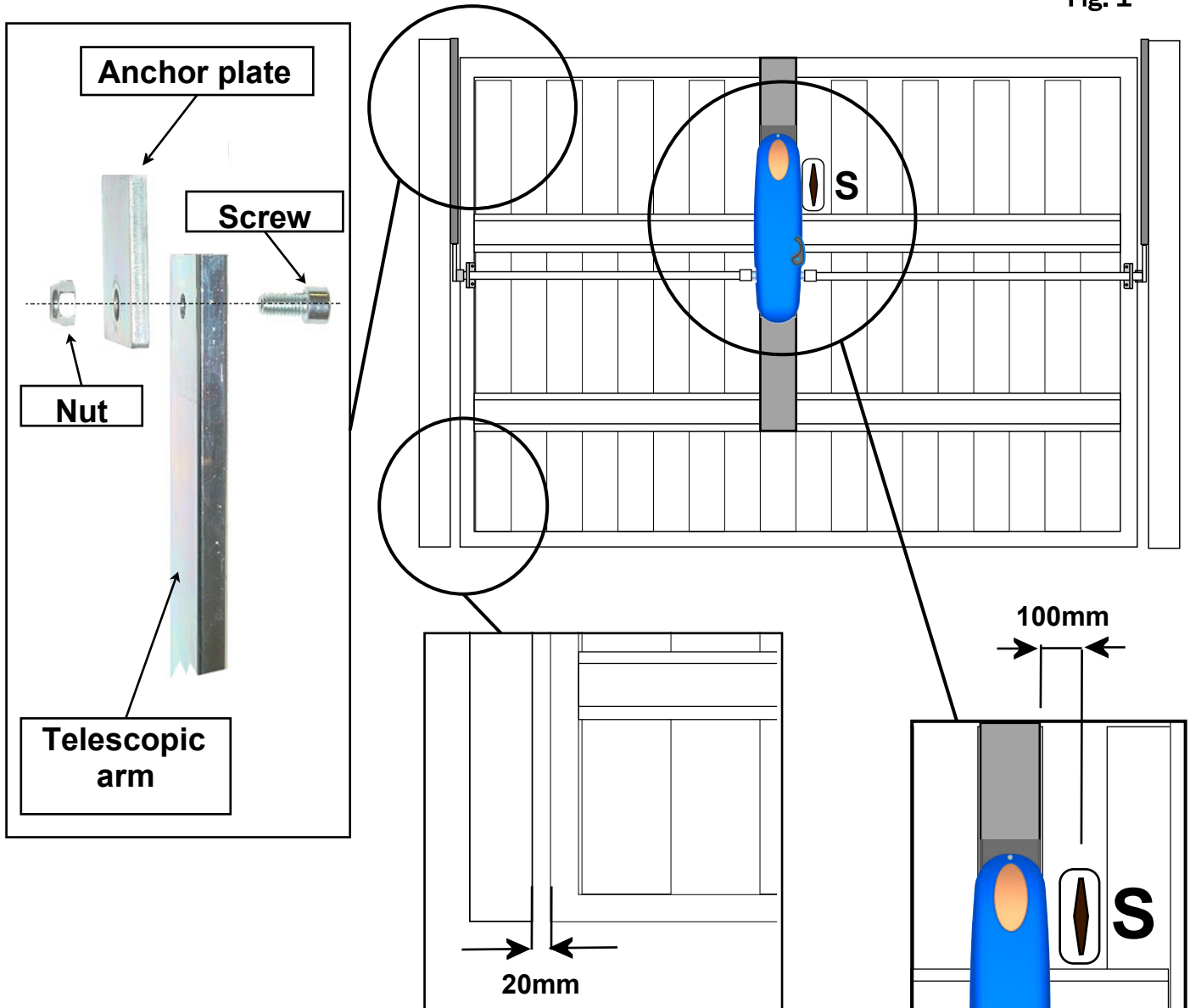

## EXAMPLE AUTOMATION ONE MOTOR WITH CENTRAL INSTALLATION

### INSTALLATION OF THE FIXING PLATE

Place the fixing plate L motor support to the door, at a distance of **100 mm** from the lock **S** of the door and fix securely.

Place and securely fix the tube support to the door frame, at a distance between **50** and **100** mm downwards by taking as reference the attachment pin of the existing arm..

Fig. 2

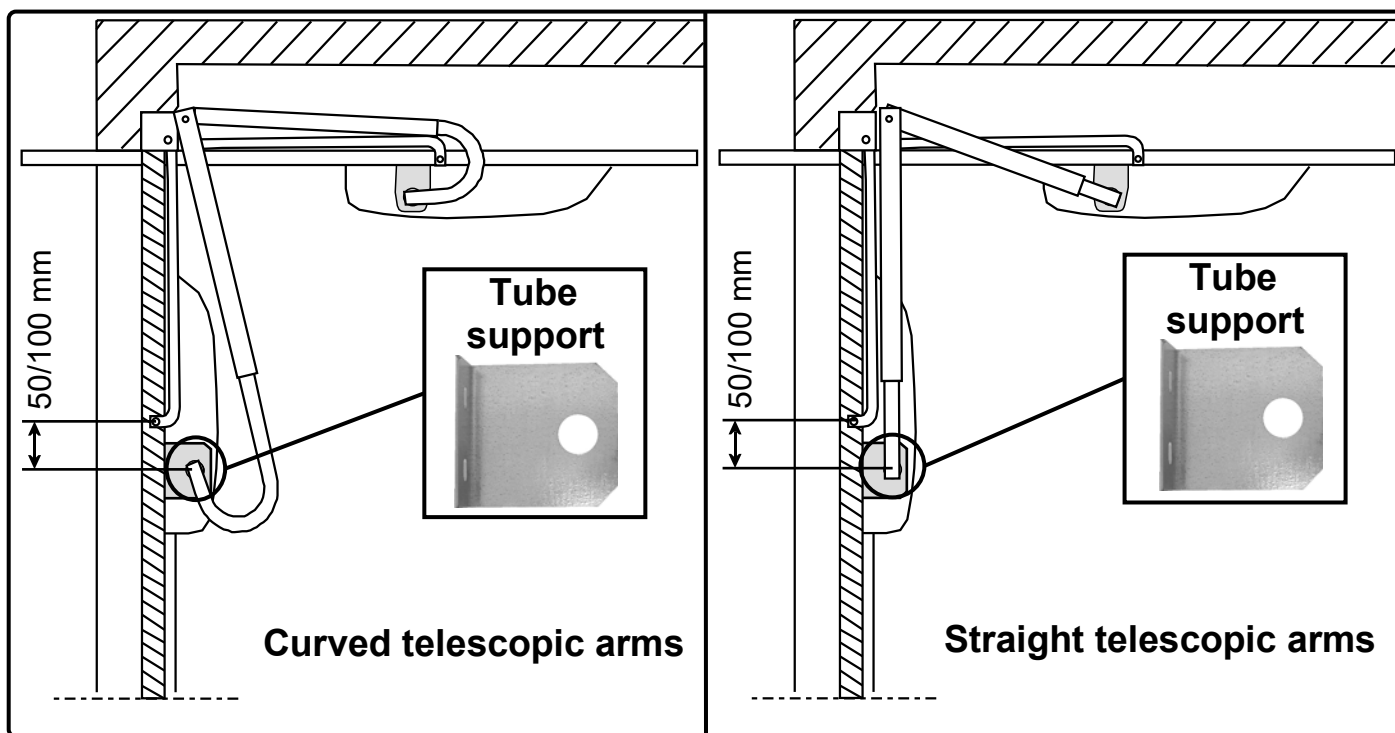

Place the motor **M** on the fixing plate so that the pinions are in line with the tubes and lock it.

Fig. 3

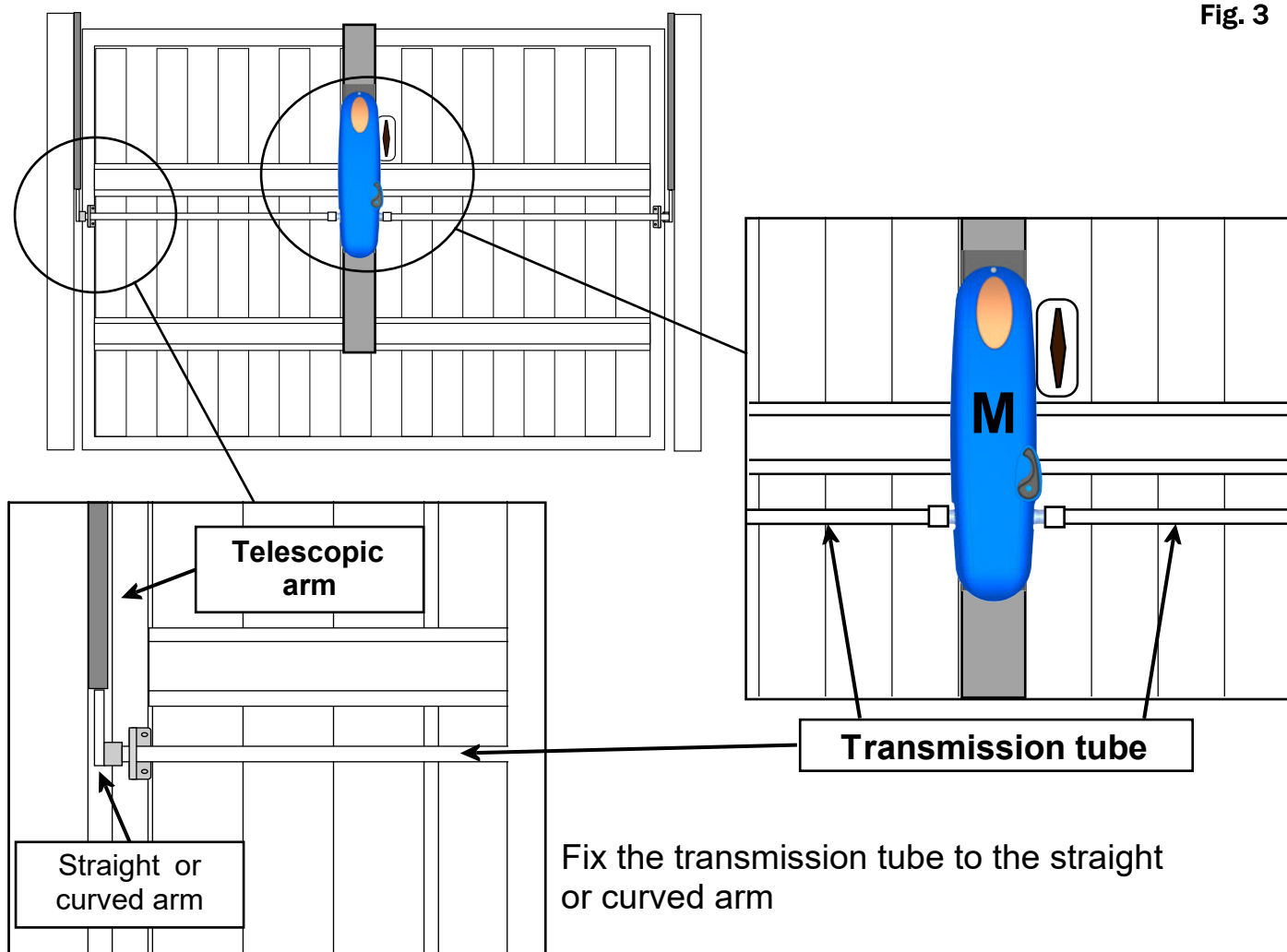

# EXAMPLE AUTOMATION TWO MOTORS WITH LATERAL INSTALLATION

## INSTALLATION OF THE LATERAL FIXING PLATES

Place the fixing plates L motor support to the door as illustrated.

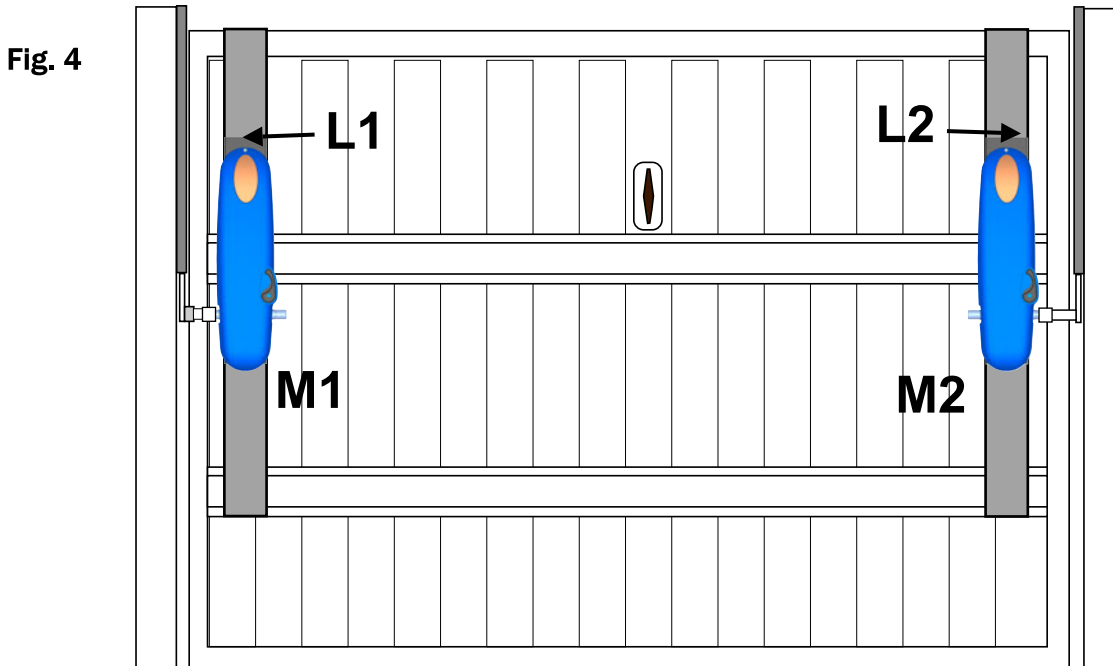

Place and fix the motors on the fixing plates so that they are in line with the broaching arms at a distance between **50** and **100** mm downwards by taking as reference the attachment pin of the existing arm (**fig 2**). Insert the broaching arms (straight or curved) on the motor shaft and lock it.

## LIMIT SWITCH ADJUSTMENT

- **Close the door.**
    - Place the limit switch (**C**) in order to touch the lever of the microswitch of the closing limit switch and tighten the screw.
  - **Open the door.**
    - Place the limit switch (**C**) in order to touch the lever of the microswitch of the opening limit switch and tighten the screw.
- (See also the specifications of the control panel)

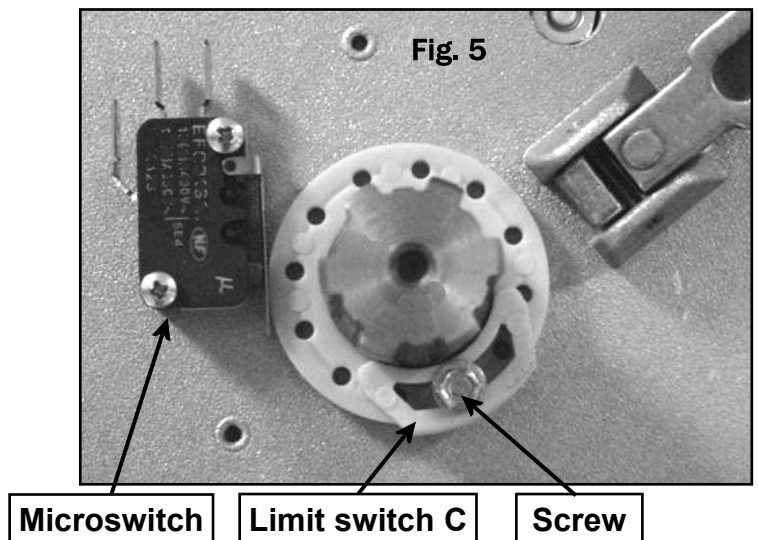

## MANUAL RELEASE

In case of lack of electric power, the motor can be manually unlocked with the lever by performing a rotation of about 90°. To block bring back the release lever to its original position.

Apply the external lock (**OPTIONAL**) to unlock the motor from the outside in case of power failure.

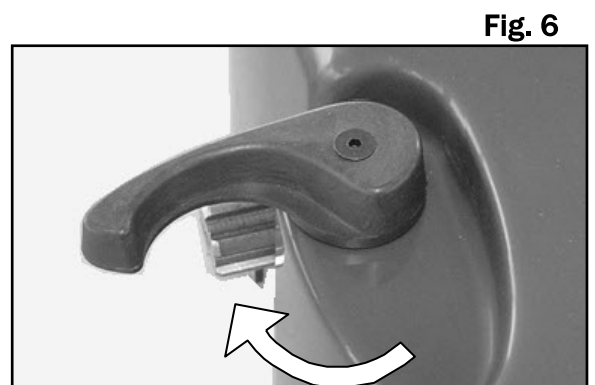

## EXAMPLE AUTOMATION WITH NON-PROJECTING DOOR

Place and securely fix the tube support to the door frame, at a distance of **110 mm** under the center of the door (**look at fig. 7-8**)

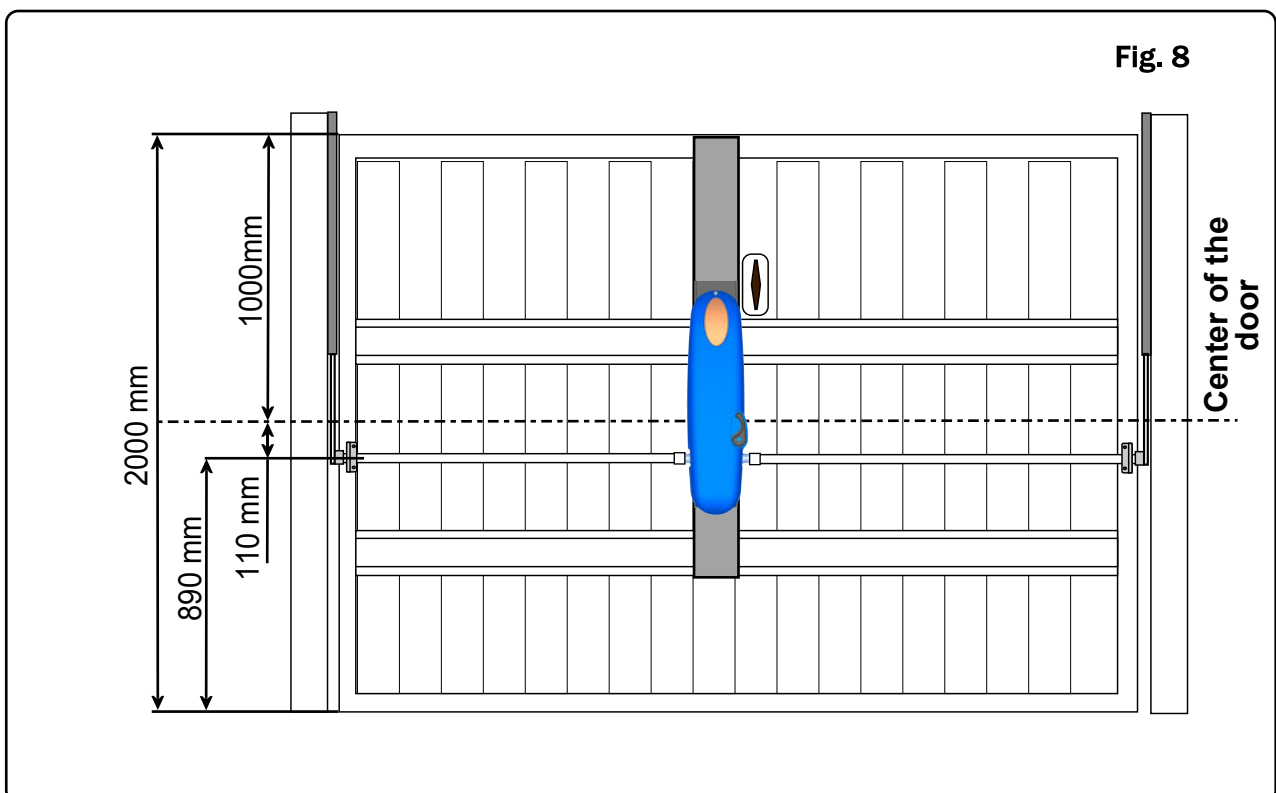
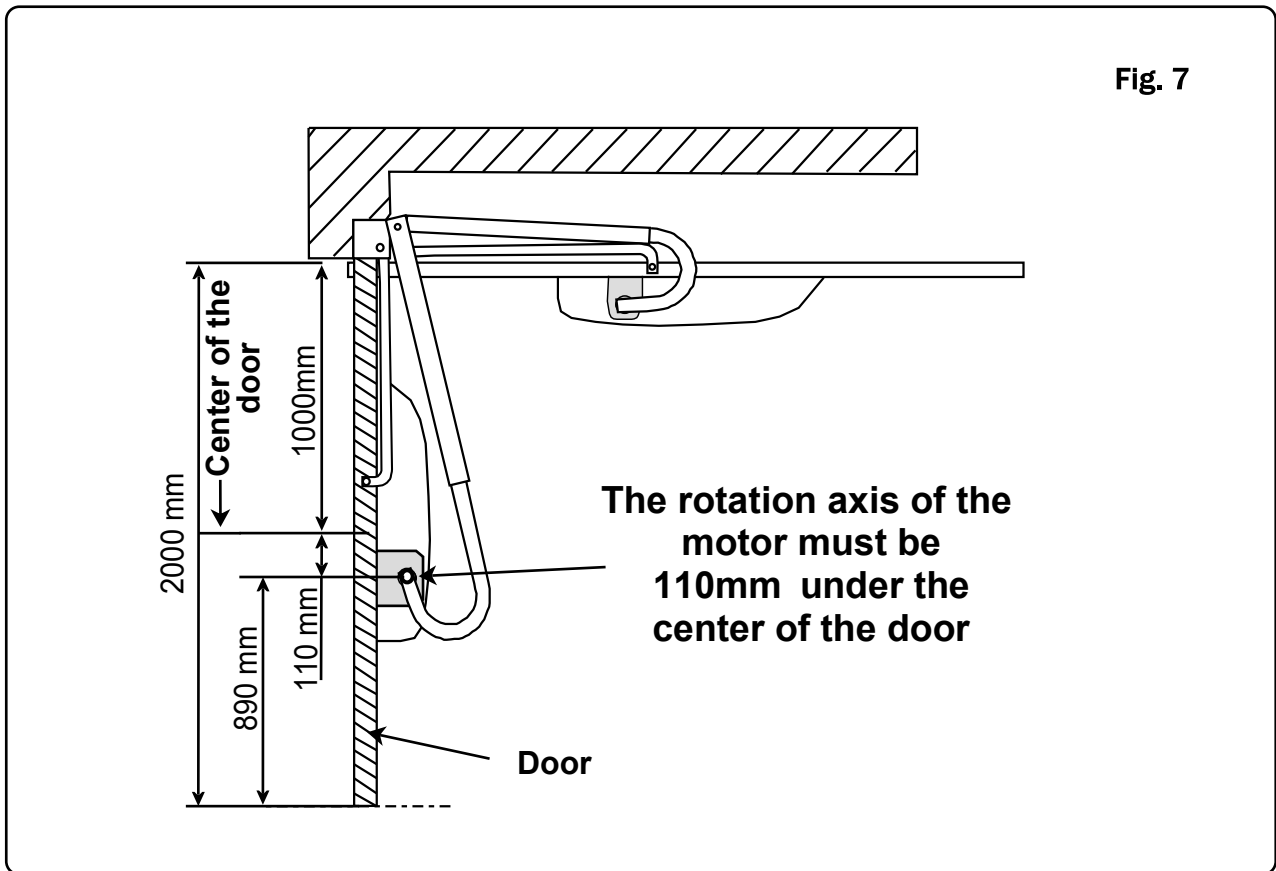

## TROUBLESHOOTING

PROBLEM	PROBABLE CAUSE	SOLUTION
On giving a command with the remote control or with the key-switch, the door doesn't open or the motor doesn't start	230 volt mains voltage absent	Check master switch
	Emergency <b>STOP</b> present	Check for any <b>STOP</b> selectors or commands. If not used, check jumper on <b>STOP</b> contact input on the control board
	Fuse blown	Replace with one of same value.
	Power cable of motor or motors not connected or faulty.	Connect the cable to appropriate terminal or replace.
	The photocell is not functioning or the beam is interrupted	Check the connection, remove any obstacle across the beam
On giving a command with the remote control, the door doesn't open but works with the key command	The remote control has not been memorised or the battery is flat	Carry out the remote control learning procedure on the radio receiver or replace the battery with a new one..
The door starts, but stops immediately	The force of the motor or motors is insufficient	Modify the value with the FORCE trimmer on the control unit
On giving a command, the motor starts, but the door does not move	There is an obstacle in front of the wings, the hinges are blocked or the motor anchorage bracket or brackets have come loose	Remove the obstacle from the wings, restore the hinges, replace or lubricate them. Fasten the motor bracket

**N.B. - If the problem persists, contact your Retailer or the nearest Service Centre**







## SAFETY PRECAUTIONS

These warnings are an essential, integral part of the product and must be given to the user. They provide important indications on the installation, use and maintenance and must be read carefully. This form must be preserved and passed on to subsequent users of the system. The incorrect installation or improper use of the product may be dangerous.

### INSTALLATION INSTRUCTIONS

- The installation must be performed by professionally skilled personnel and in compliance with current local, state, national and European legislation.
- Before beginning the installation, check the integrity of the product.
- The laying of cables, electrical connections and adjustments must be workmanlike performed.
- The packing materials (cardboard, plastic, polystyrene, etc.) are a potential hazard and should be disposed of correctly and not left within reach of children.
- Do not install the product in potentially explosive environments or environments disturbed by electromagnetic fields. The presence of inflammable gases or fumes is a grave danger to safety.
- Set up a safety device for overvoltage, a disconnecting and/or differential switch suitable for the product and conforming to current standards.
- The manufacturer declines any and all responsibility for product integrity, safety and operation in the event incompatible devices and/or components are installed.
- Solely original spare parts should be used for repairs and replacements.
- The installer must provide all the information relating to the operation, maintenance and use of the individual parts, components and system as a whole.

### WARNINGS FOR THE USER

- Read the instructions and enclosed documentation carefully.
- The product must be used for the express purpose for which it was designed. Any other use is considered improper and therefore hazardous. In addition, the information given in this document and in the enclosed documentation may be subject to modifications without prior notice. It is given as an indication only for product application. The company declines any responsibility for the above.
- Keep products, devices, documentation and anything else provided out of reach of children. In the event of maintenance, cleaning, breakdown or faulty operation of the product, cut off the power and do not attempt to operate on the product. Contact solely the professionally skilled personnel responsible for these operations. Failure to adhere to the above indications may be dangerous.

All products are guaranteed for 2 years, as per the date on the invoice or on the receipt.

The warranty also does not include: failures or damages caused by faults of the electrical system and/or carelessness, negligence or inadequacy of the installation to the use for which it is intended and in any case from abnormal use; failures or damages due to tampering by unauthorized personnel or the use of components not attributable to the manufacturer and/or non-original spare parts; **defects caused by chemical agents, external bodies or atmospheric and/or natural phenomena in general**; failures or damages caused by incorrect installation of the Products according to the rule of art, safety and conformity of use expressly indicated in the technical documentation of the same Products; the consumables; interventions for checks and assessments of any flaws or defects then not found; compensations for the period of inactivity of the system where the Products are installed.

**The data and images are for guidance only  
VDS reserves the right to change at any time characteristics of the products described in  
its sole discretion, without notice.**



**Via Circolare p.i.p. N° 10  
65010 Santa Teresa di Spoltore (PE) - ITALY  
Tel. +39 085 4971946 - FAX +39 085 4973849  
[www.vdsautomation.com](http://www.vdsautomation.com) - [info@vdsautomation.it](mailto:info@vdsautomation.it)**