

# TECHNICAL INSTALLATION MANUAL

## AUTOMATION FOR BARRIERS

# BERTA



**WARNING!!** Before installing, thoroughly read this manual that is an integral part of the pack

Our products if installed by qualified personnel capable to evaluate risks, comply with norms UNI EN 12453, EN 12445



The CE mark conforms to European directive  
EEC 89/336 + 92/31 + 93/68 D.L. 04/12/1992 N. 476.

# INDEX

Pag.

PACKING CONTENTS .....	2
TECHNICAL DATA.....	2
DIMENSIONS .....	3
CONSIDERATIONS FOR INSTALLATION.....	3
INSTALLATION.....	4-5-6-7
TROUBLESHOOTING.....	8
SAFETY PRECAUTIONS .....	12

## PACKING CONTENTS

1- BARRIER



1- BAR SUPPORT

1- UNLOCKING KEY



1- CONDENSER ( 230Vca version)

## TECHNICAL DATA

	BERTA		BERTA FAST VERSION	
	230V	24V	230V	24V
Maximum length of bar	6 mt		4 mt	
Motors power supply	230Vac	24Vdc	230Vac	24Vdc
Motor power	250 W	60W	250 W	60W
Motor RPM	1400	1800	1400	3000
Condenser	12,5 µF	/	12,5 µF	/
Mechanical unlock for emergency manoeuvre	Mechanical			
Working temperature	-20° C / +55° C			
Weight	45Kg			
Protection rating	IP 44			
Limit switch	Electromechanical			
Opening time	10 sec		5 sec	

---

## DIMENSIONS

---

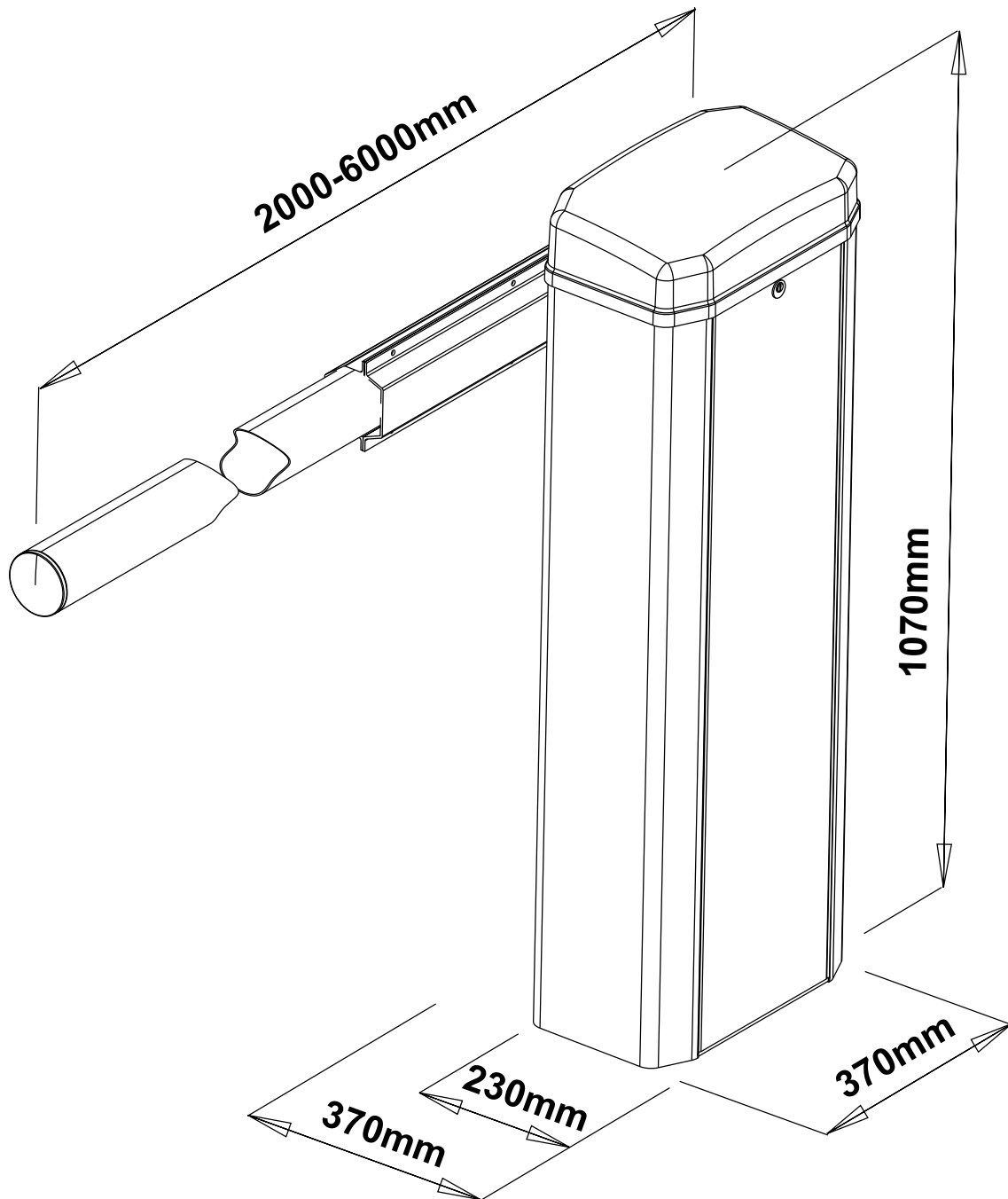

---

## CONSIDERATIONS FOR INSTALLATION

---

- The installation and testing operations must be performed by qualified personnel in order to guarantee the proper and safe operation of the automatic gate.
- The company declines any responsibility for damage caused by incorrect installations due to incompetence and/or negligence.

## INSTALLATION

Set up an electrical multi-duct conduit in the middle of the foundation of the barrier, corresponding to the central hole (corrugated - diameter 25 - 50mm).

### **INSTALLATION WITH BASE PLATE (OPTIONAL)**

Take the floor plate and bend the brackets as needed. Dig a suitably sized hole in the ground. Insert the electrical conduit into the cable conduit hole of the floor plate. Level and cement the floor plate.

Place the barrier on the floor plate and fasten it with the self-locking M12 nuts supplied.

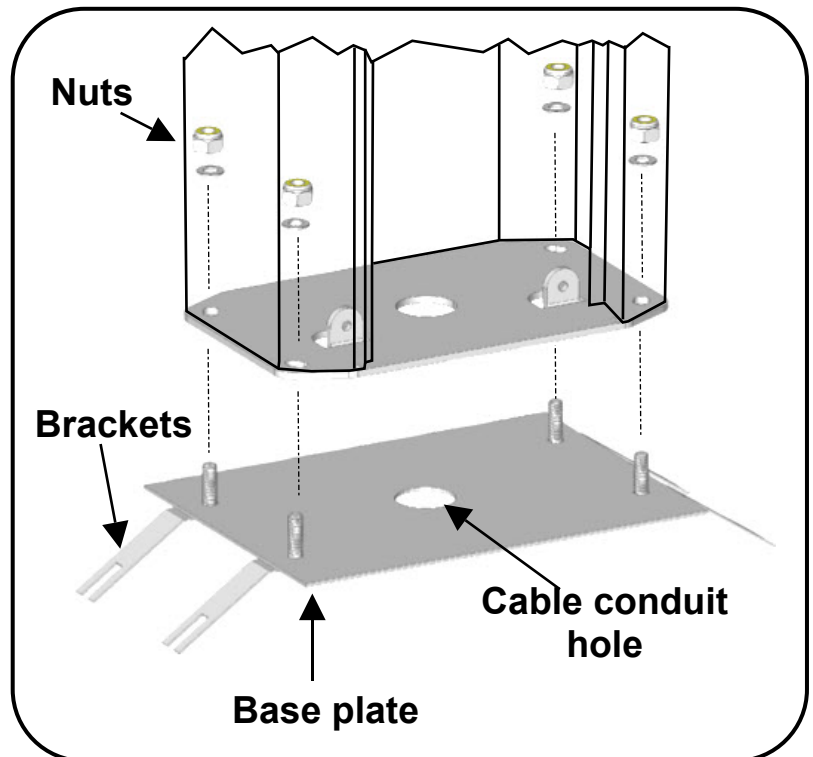

### **INSTALLATION WITHOUT BASE PLATE**

Place the barrier and block it through the four holes present internally on the basis.

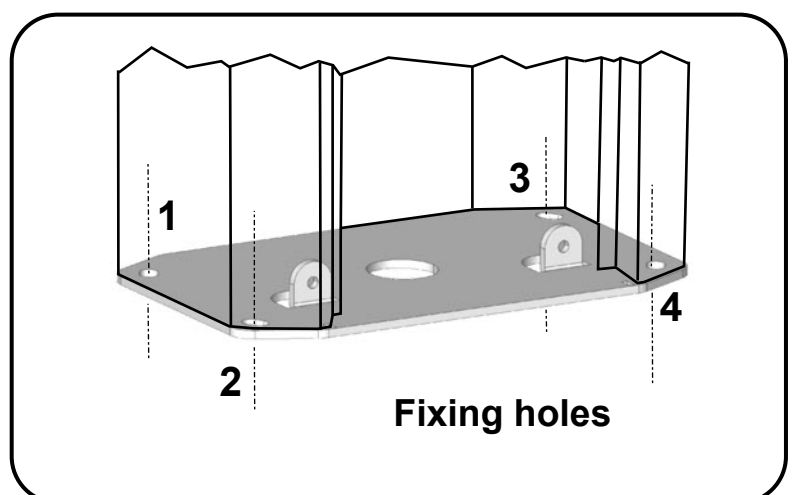

## MANUAL OPENING

Open the cover with the key.

insert unlocking key and turn clockwise as in the picture below.

**Please note that when the cover is opened the operator goes into block**

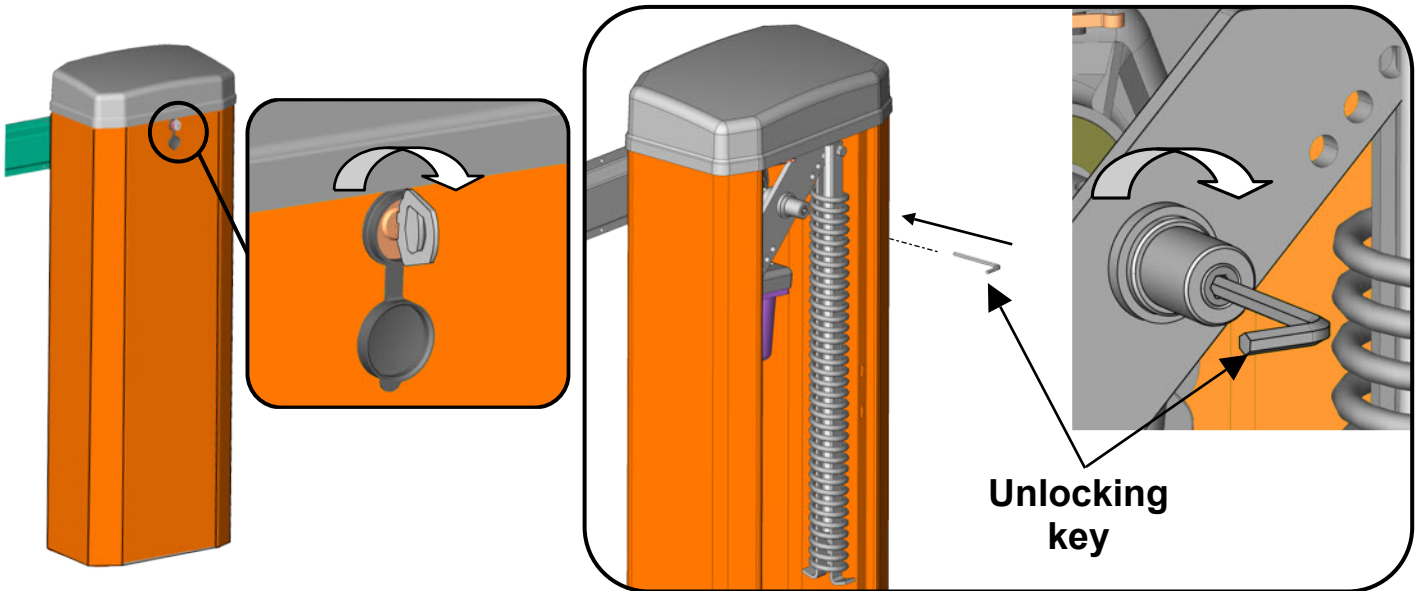

## BAR SUPPORT INSERTION

- Insert the spacer (1) on the shaft
- Insert the key (2) in the shaft seat
- Insert the boom support (3) and firmly tighten the two dowels (4)
- Couple the front part of the support (5)
- Insert the boom (6) and firmly tighten the 4 screws with nuts and washers (7)
- Insert and block the casing (8) with the screws (9)

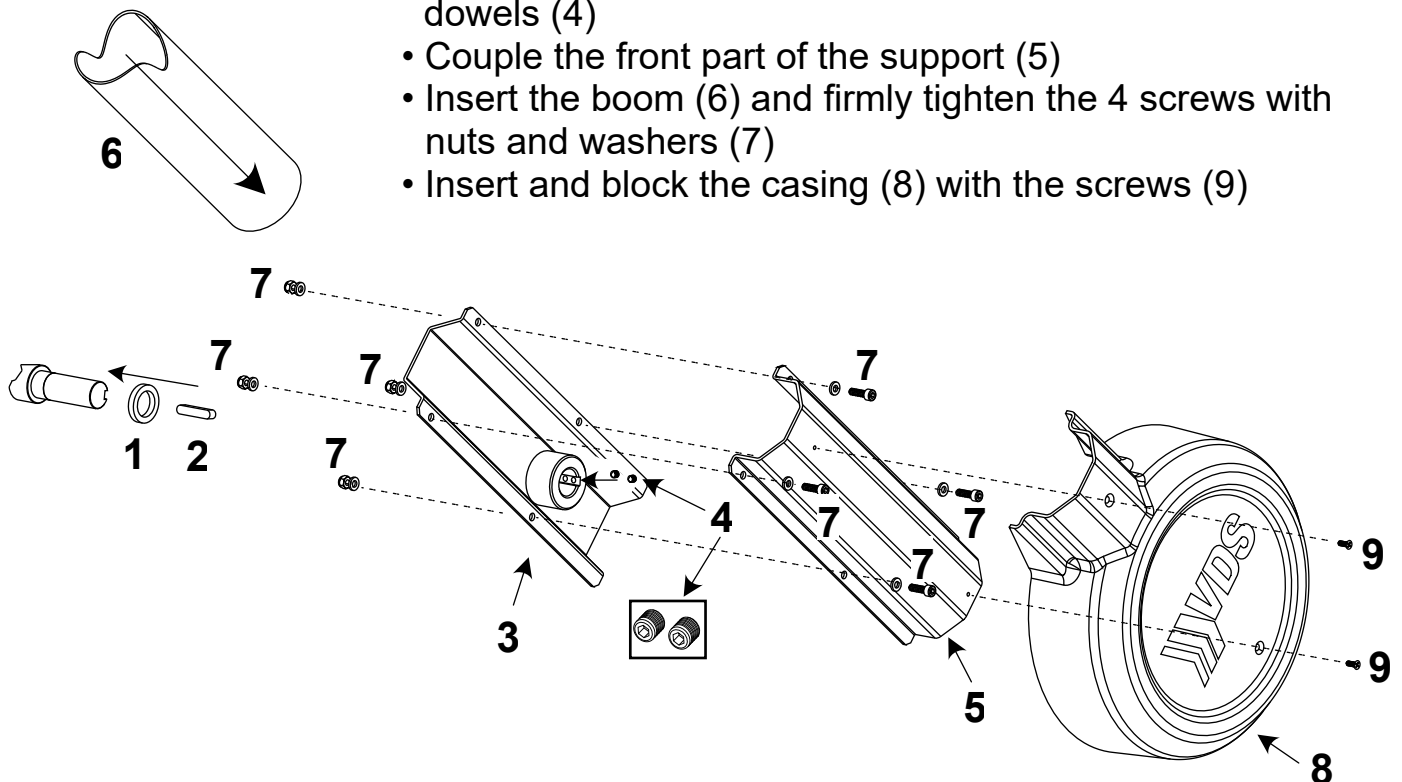

## OPENING DIRECTION

To change the direction of opening from the **left** (standard) to the **right** proceed as follows:

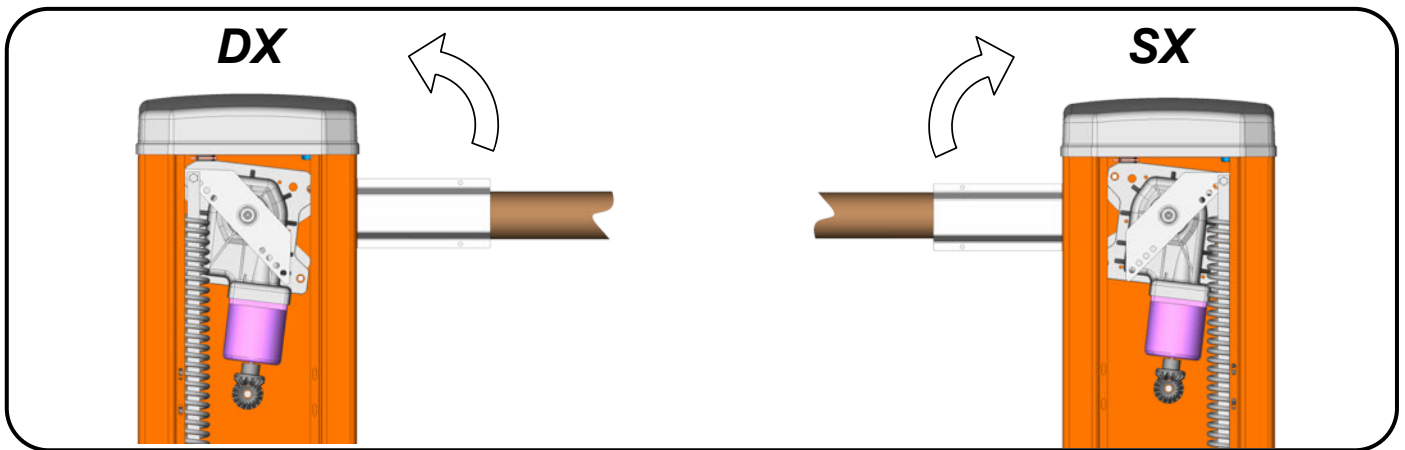

- Release the spring
- Remove the trapezoidal bracket by unscrewing the two screws.
- Change the position of the key from position **A** to position **B**

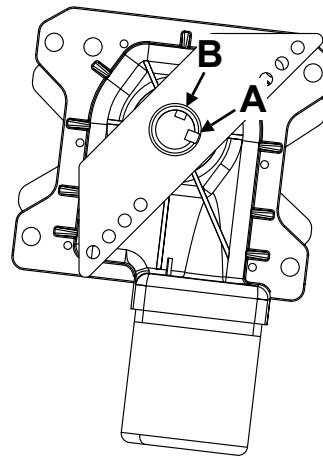
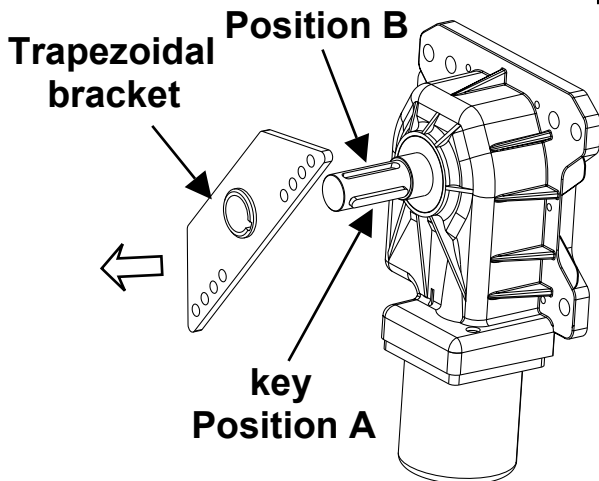
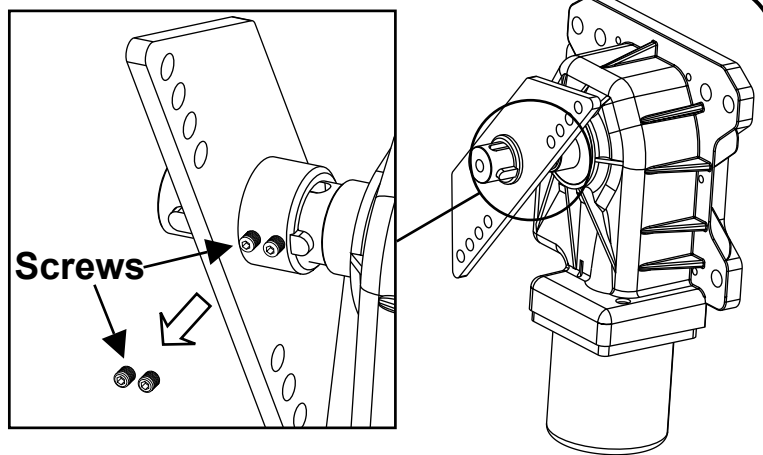

- Replace the trapezoidal bracket and tighten the screws
- Hook the spring in the opposite position (holes **B**)

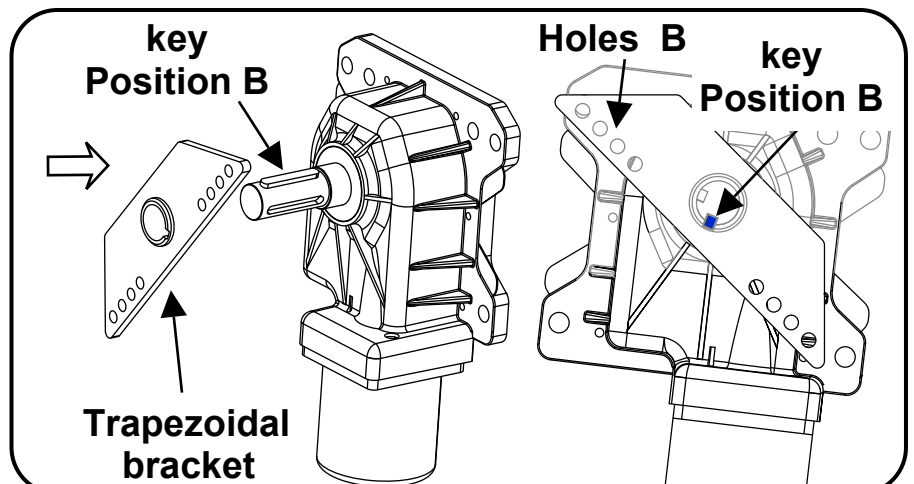

## SPRING REGULATION

- Release the operator
- Acting on the lower tie nut, put the spring in tension until the rod is balanced at 45° and the trapezoidal bracket will remain horizontal to the ground.
- Block the motor

The trapezoidal bracket has four holes which regulate the force of the spring according to the length of the bar. The force of the spring is reduced the more it is placed internally.

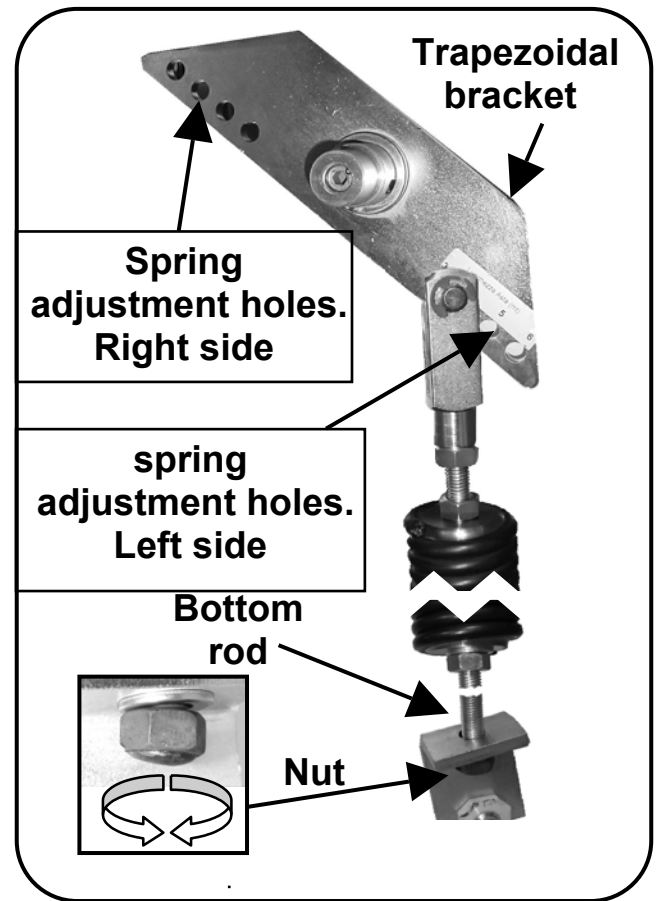

## LIMIT SWITCHES REGULATIONS

It's possible to adjust the limit switches position, both the mechanical (*placed inside the barrier*) and electrical ones (*easily accessible, as they are placed under the superior cover*).

**N.B. When one of the mechanical end-stroke switches is repositioned, it is necessary to relocate the electronically controlled one accordingly, and then repeat the stroke selecting procedure**

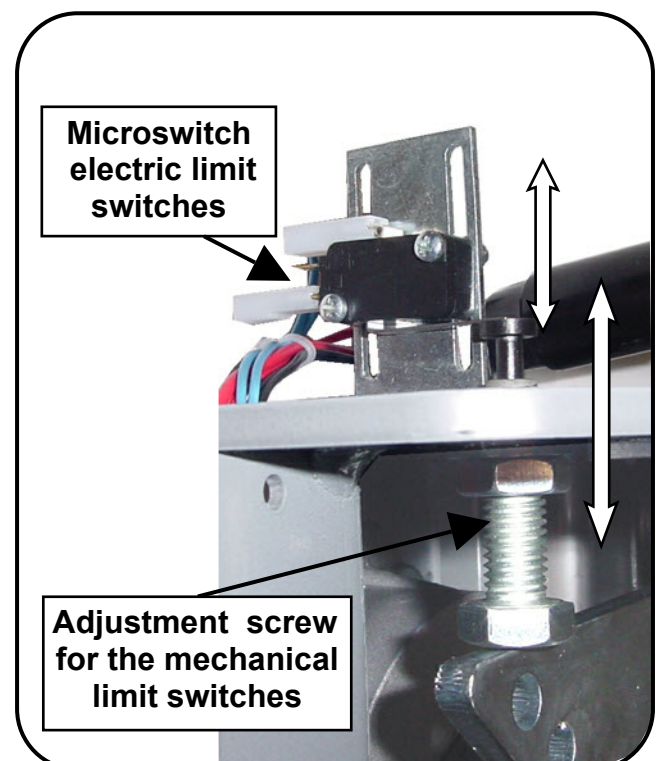

## TROUBLESHOOTING

PROBLEM	PROBABLE CAUSE	SOLUTION
<b>On giving a command with the remote control or with the key-switch, the barrier doesn't open or the motor doesn't start</b>	<b>230 volt mains voltage absent</b>	<b>Check master switch</b>
	<b>Emergency STOP present</b>	<b>Check for any STOP selectors or commands. If not used, check jumper on STOP contact input on the control board</b>
	<b>Fuse blown</b>	<b>Replace with one of same value.</b>
	<b>Power cable of motor or motors not connected or faulty.</b>	<b>Connect the cable to appropriate terminal or replace.</b>
	<b>The photocell is not functioning or the beam is interrupted</b>	<b>Check the connection, remove any obstacle across the beam</b>
<b>On giving a command with the remote control, the barrier doesn't open but works with the key command</b>	<b>The remote control has not been memorised or the battery is flat</b>	<b>Carry out the remote control learning procedure on the radio receiver or replace the battery with a new one..</b>
<b>The barrier starts, but stops immediately</b>	<b>The force of the motor or motors is insufficient</b>	<b>Modify the value with the FORCE trimmer on the control unit</b>

**N.B. - If the problem persists, contact your Retailer or the nearest Service Centre**







## **SAFETY PRECAUTIONS**

These warnings are an essential, integral part of the product and must be given to the user. They provide important indications on the installation, use and maintenance and must be read carefully. This form must be preserved and passed on to subsequent users of the system. The incorrect installation or improper use of the product may be dangerous.

## **INSTALLATION INSTRUCTIONS**

- The installation must be performed by professionally skilled personnel and in compliance with current local, state, national and European legislation.
- Before beginning the installation, check the integrity of the product.
- The laying of cables, electrical connections and adjustments must be workmanlike performed.
- The packing materials (cardboard, plastic, polystyrene, etc.) are a potential hazard and should be disposed of correctly and not left within reach of children.
- Do not install the product in potentially explosive environments or environments disturbed by electromagnetic fields. The presence of inflammable gases or fumes is a grave danger to safety.
- Set up a safety device for overvoltage, a disconnecting and/or differential switch suitable for the product and conforming to current standards.
- The manufacturer declines any and all responsibility for product integrity, safety and operation in the event incompatible devices and/or components are installed.
- Solely original spare parts should be used for repairs and replacements.
- The installer must provide all the information relating to the operation, maintenance and use of the individual parts, components and system as a whole.

## **WARNINGS FOR THE USER**

- Read the instructions and enclosed documentation carefully.
- The product must be used for the express purpose for which it was designed. Any other use is considered improper and therefore hazardous. In addition, the information given in this document and in the enclosed documentation may be subject to modifications without prior notice. It is given as an indication only for product application. The company declines any responsibility for the above.
- Keep products, devices, documentation and anything else provided out of reach of children. In the event of maintenance, cleaning, breakdown or faulty operation of the product, cut off the power and do not attempt to operate on the product. Contact solely the professionally skilled personnel responsible for these operations. Failure to adhere to the above indications may be dangerous.

**All products are guaranteed for 2 years, as per the date on the invoice or on the receipt.**

**The warranty also does not include: failures or damages caused by faults of the electrical system and/or carelessness, negligence or inadequacy of the installation to the use for which it is intended and in any case from abnormal use; failures or damages due to tampering by unauthorized personnel or the use of components not attributable to the manufacturer and/or non-original spare parts; defects caused by chemical agents, external bodies or atmospheric and/or natural phenomena in general; failures or damages caused by incorrect installation of the Products according to the rule of art, safety and conformity of use expressly indicated in the technical documentation of the same Products; the consumables; interventions for checks and assessments of any flaws or defects then not found; compensations for the period of inactivity of the system where the Products are installed.**

**The data and images are for guidance only  
VDS reserves the right to change at any time characteristics of the products described in  
its sole discretion, without notice.**



**Via Circolare p.i.p. N° 10  
65010 Santa Teresa di Spoltore (PE) - ITALY  
Tel. +39 085 4971946 - FAX +39 085 4973849  
[www.vdsautomation.com](http://www.vdsautomation.com) - [info@vdsautomation.com](mailto:info@vdsautomation.com)**

